

Controlled release of stored pulses in a double quantum-well structure

F. Carreño^{1*}, M. A. Antón¹, F. Arrieta-Yáñez¹, Oscar G. Calderón¹, S. Melle¹, I. Gonzalo, M.A. Porras²

1: Escuela Universitaria de Óptica, UCM, Madrid, Spain

2: Escuela Técnica Superior de Ingenieros de Minas, UPM, Madrid, Spain

*ferpo@fis.ucm.es

Keywords: Slow light, pulse storage, quantum-well structures, Fano interferences

It has been well established that a light pulse propagating through a medium composed of three-level atoms in the Λ configuration, suitably driven by another auxiliary field, can be stopped and later released in a controlled way (see Ref. [1]). The process may be interpreted either in terms of inducing transient Raman coherence between two lower atomic states or by considering an adiabatic evolution of the so-called dark state polariton. Storage and retrieval of weak probe fields have been reported in EIT based cold atomic clouds [2], thermal gases [3] as well as in solid media. Other multilevel scheme such as double-Lambda, tripod [4] and inverted-Y atomic systems [5] has also been considered.

The control of light propagation in a variety of semiconductor-based systems using different physical mechanisms has been successfully demonstrated. These include slow light by coherent population oscillation (CPO) in semiconductor quantum wells (QWs) [6,7,8]. In this work we analyze the possibility of optical and voltage-controlled light storage and retrieval of optical pulses in an asymmetric double quantum-well structure driven by a coherent control field and a weak probe field where transparency can be achieved through two different mechanisms: via electromagnetically induced transparency and/or via vacuum induced coherence arising from Fano-type interferences.

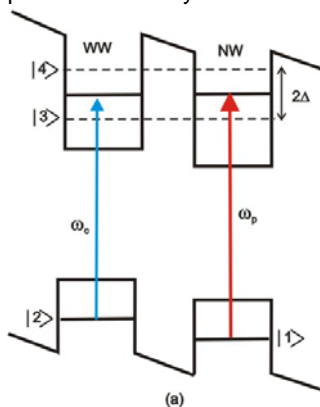

We analyze the feasibility of such a process by considering a semiconductor structure formed by several periods of a n-doped double QW structure schematically depicted in Fig 1. This structure has been previously analysed in Ref. [9] and it consists of two quantum wells that are separated by a narrow barrier. The system can be modelled by means of a four-level system where $|1\rangle$ and $|2\rangle$ are the ground state of the deep well and the first excited state of the shallow well, respectively. The states $|3\rangle$ and $|4\rangle$ are the result of mixing the ground state of the shallow well and the first excited state of the deep well when considered isolated each other. The use of an auxiliary control field together with the possibility to manipulate externally the splitting of the upper levels allows to transfer the electromagnetic excitation into a certain combination of coherences. The system may operate in different regimes according to the writing-reading protocol of the control parameters.

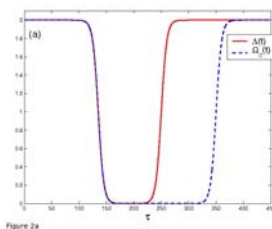
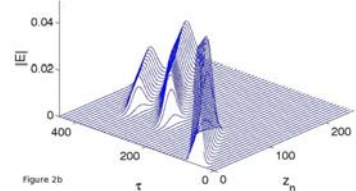

Figure 2(a)/(b) displays the temporal variation of the control parameters/modulus of the incoming pulse. The pulse is stored in the medium by allowing for the simultaneous change of the upper level splitting and the control field. The pulse is stopped inside the medium and is released by changing the upper level splitting while keeping constant the control field. Another pulse is released from the medium by turning on later in time the control field.



Acknowledgment.

This work has been supported by Projects no. FIS2007-65382 (MEC), PR34/07-15847 (UCM-BSCH), CCG08-UCM/ESP-4220, and GR58/08 910133-1030(BSCH-UCM) from Spain.

[1] M. Lukin, Rev. Mod. Phys. 75 , 457 (2003).

[2] C. Liu, Z. Dutton, C.H. Behroozi, L.V. Hau, Nature London 409, 490, (2001)

[3] D.F. Phillips, A. Fleischhauer, A. Mair, R.L. Walsworth,; M.D. Lukin, Phys. Rev. Lett. 86 783, (2001)

[4] A. Raczyński, J. Zaremba, S. Zielinska-Kaniasty, Phys. Rev. A 75 013810, (2007)

[5] A. Joshi, M. Xiao, Phys. Rev. A 71 041810 (R), (2005); P.C. Ku, F. Sedgwick, C.J. Chang-Hasnain, P. Palinginis, T. Li, H. Wang, S-W Chang and S-L Chuang Opt. Lett. 29, 2291, (2004).

[6] P. Palinginis, F. Sedgwick, S. Crankshaw, M. Moewe and C.J. Chang-Hasnain, Opt. Express 13, 9909, (2005).

[7] P. Palinginis, S. Crankshaw, F. Sedgwick, E-T Kim, M. Moewe, C.J. Chang-Hasnain, H. Wang and S-L Chuang Appl. Phys. Lett. 87 171102, (2005).

[8] J. Mork, R. Kjaer, M. Van Der Poel and K. Yvind Opt. Express 13, 8136, (2005).

[9] W. X. Yang, J. Xu, and R. k. Lee, arXiv:0803.1888v1 (Oct. 2008)